

Product Data Sheet

600A GP XX

Replace "XX" with 01 through 22 for number of poles

Terminal Block– Open Back
15 Amps, 300 Volts (AC/DC)



Insulator Strip Required for Voltage Rating

Copper Wire Only

Wire Range with Wire Binding Screw: #12 - #22 AWG

3/8" Centers

Application torque: 9 in. lbs

Electrical Ratings:

- 15A with Listed ring lug or unprepared wire, (Based on NEC Table 310-16, 75°C columns)
- 300 Volts AC/DC (UL 1059 Class B, User Group – Commercial Appliances)
- Short Circuit Current Rating: 10,000A (Default)
 - Approved for Factory and Field Wiring with Solid Wire
 - Approved for Factory Wiring with Stranded Wire

Mechanical Ratings:

- Storage and transportation temperature range: -35°C to 110°C (-31°F to 230°F)*
- Maximum insulator base temperature: 150°C (302°F)* UL RTI
- Flammability rating of insulator base: UL 94V-1

* Use outside these ratings needs to be judged in the end-use application.

Materials:

- Connector (Eyelet): Brass, nickel plated.
- Insulator base: Phenolic
- Screw, #6-32 Binder head, Phil-Slot: Steel, nickel plated

Agency Approvals:

- UL Recognized, UL 1059 Terminal Block Standard, File No. XCFR2.47811

- CSA Certified, CSA C22.2 No. 158, File No. LR19766
- CE compliant, IEC 60947-7-1
- RoHS Compliant

Wire Range:

Wire Size	Torque	Copper Wire Stranding Classes - Number of Strands		
		Solid	Class B	Class C
12	9 in. Lbs	1	7	19
14	9 in. Lbs	1	7	19
16	9 in. Lbs	1	7	19
18	9 in. Lbs	1	7	19
20	9 in. Lbs	1	7	19
22	9 in. Lbs		7	19

Suggested product mounting hardware: #6 fastener, torque to 10-15 in. lbs.

ACCESSORIES:

- JJ (GDI-30F) Material available. Glass-fiber filler, diallyl ortho-phthalate. UL-94 V0. Certifiable to Military Specifications MIL-M-14 and MIL-P-19833.

- Marking strips - sub mounted, black only (FB)

- Marking strips – top mounted, white only (SW)

- Insulator strips - sub mounted, black only (BB) (Printing Unavailable) the same width as the molding.

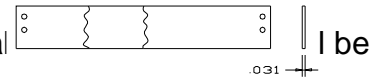

- Cover – top mounted. Order CW (white) or CB (Black).

- Phil-Slot Brass Screw (PSB)



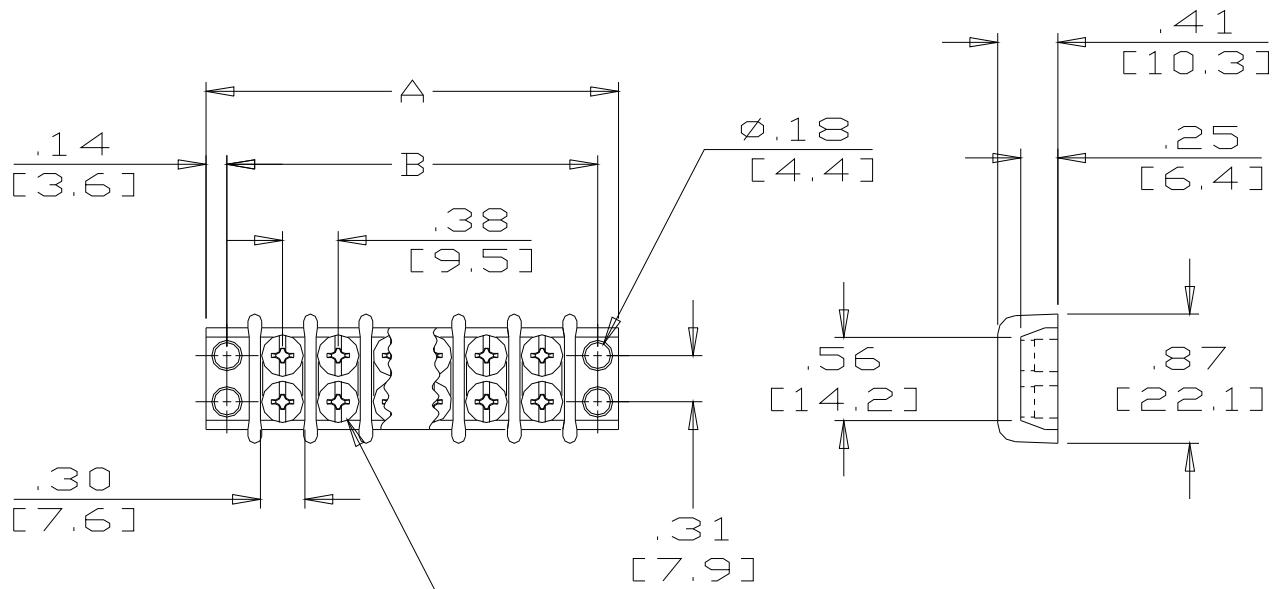

#6-32 X .25 [6.4] BD HD SCREW

Catalog No	# of Poles	Dimensions			X	Catalog No	# of Poles	Dimensions	
		A	B					A	B
600A GP 01	1	1.03	0.75	X	600A GP 12	12	5.16	4.88	
600A GP 02	2	1.41	1.13	X	600A GP 13	13	5.53	5.25	
600A GP 03	3	1.78	1.50	X	600A GP 14	14	5.91	5.63	
600A GP 04	4	2.16	1.88	X	600A GP 15	15	6.28	6.00	
600A GP 05	5	2.53	2.25	X	600A GP 16	16	6.66	6.38	
600A GP 06	6	2.91	2.63	X	600A GP 17	17	7.03	6.75	
600A GP 07	7	3.28	3.00	X	600A GP 18	18	7.41	7.13	
600A GP 08	8	3.66	3.38	X	600A GP 19	19	7.78	7.50	
600A GP 09	9	4.03	3.75	X	600A GP 20	20	8.16	7.88	
600A GP 10	10	4.41	4.13	X	600A GP 21	21	8.53	8.25	
600A GP 11	11	4.78	4.50	X	600A GP 22	22	8.91	8.63	

Top Mounted Hardware is .187" Wide

MM = Dim X 25.4